



Product Information

PRODUCT SERIES: LS- 20

Industrial Engine Control Unit

The LS-20 is a full-feature engine management system designed for dual fuel industrial engine applications. It provides electronic drive-by-wire engine speed control, LP and gasoline fuel control, and electronic ignition timing control.

Engine over-temperature, oil pressure and foot pedal fault detection is available. Programming and diagnostics of this Digital controller is performed via laptop PC or hand held monitor. Once calibrated to engine and vehicle requirements this tamper proof unit is capable of compliance with proposed EPA regulations.



Inputs:

- RPM trigger input 12V square wave or ignition coil signal
- Integral manifold absolute pressure sensor
- Pedal position sensor input
- Engine temperature compensation
- Lambda sensor input

Outputs:

- Electronic governor control signal
- Air/fuel ratio control signal
- Optional LP injection control
- LP lockout valve control
- Check engine light
- Gasoline fuel injection control
- Distributorless ignition timing control

FEATURES

- Full authority engine management
- Drive-by-wire speed control
- Closed loop air/fuel ratio control
- Electronic ignition timing control
- Map sensor for altitude compensation
- Engine temperature compensation
- Engine diagnostics

BENEFITS

- Tier I and Tier II emission compliance capability
- Optimized engine performance
- Improved driveability
- Low cost compliance solution

Barber-Colman DYNA Products
P.O. Box 2940
1354 Clifford Avenue
Loves Park, IL 61132-2940
USA

Tel: + 1 815 637 3000
Fax: + 1 815 877 0150
www.dynaproducts.com

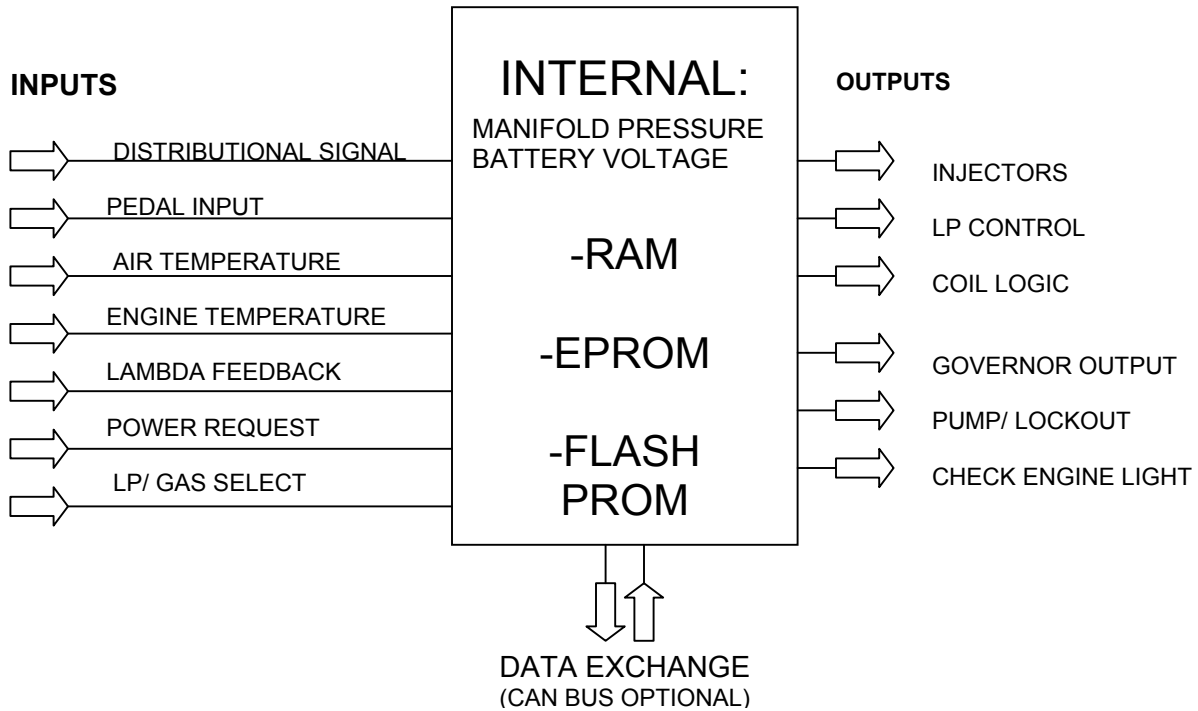

Controller Specifications

Operating Voltages: 8 -16 VDC

Storage Temperature: -60°C to 125 °C

Operating Temperature: -40°C to +85°C

Engine Speed Range: 90 to 6375 RPM

Electromagnetic Compatibility: Meets EN50081-1, EN650082-2 for industrial trucks

Sealing: Oil, Water, and dust resistant via polyurethane potting and aluminum enclosure.

Humidity: 90% RH, 8 hour test per MIL-STD-810D

Dust Contamination resistance: .88 g/m³ for 24 Hr per SAE 1455

Drop test: 1m in 3 axis per SAE 1455

Mechanical Vibration: Suitable for mounting per SAE J1455

- CAUTION -

As a safety measure, the engine should be equipped with an independent overspeed shutdown device in the event of failure which may render the governor inoperative.

- NOTE -

Barber-Colman believes that all information provided herein is correct and reliable but reserves the right to update at any time. Barber-Colman does not assume any responsibility for its use unless otherwise expressly undertaken.